



MAKES
UP TO 4
CUPS

aerolatte[®] grande

instruction manual

The *aerolatte*[®] grande heat & froth machine whisks while it warms to make delicious frothed milk for **up to four cups** of cappuccinos, caffè lattes and hot chocolates from ordinary cold milk. Using the tried and tested *aerolatte*[®] frothing head, you can be assured of the perfect hot frothed milk brought to you from the company that introduced the world to steam free milk frothing.

Safety Instructions and WARNINGS

When using electrical appliances basic safety precautions should always be followed including the following. Although some of these points seem self evident, we are required to bring them to your attention and it is important that you read and understand all these instructions before using your *aerolatte*[®] compact heat & froth machine. You should also keep these instructions with your *aerolatte*[®] compact milk frother for future reference.

- This appliance must be earthed. It comes fitted with an earthed plug. Do not remove the plug and ensure you insert it in a professionally installed, earthed socket supplying the correct voltage.
- To protect against fire, electric shock and injury to persons do not immerse cord, plugs, power base or jug base in water or other liquids or place in the dishwasher as there will be a **danger of short-circuiting!**
- Never operate damaged appliances (including mains cables).
- Do not operate this appliance with a damaged cord or plug or after the appliance malfunctions or has been damaged in any manner. Return the appliance to the nearest authorized service facility for examination, repair or adjustment.. If the supply cord is damaged, it must be replaced by manufacturer, its service agent or similarly qualified person in order to avoid a hazard.
- Never touch live parts or hot surfaces.
- Do not use extension cables.
- Never let mains cord hang loose over the edge of a table or counter, nor remove plug with wet hands, nor lay or hang on hot surfaces, nor let it come into contact with oils.
- Unplug the appliance and allow it to cool:
 - after each use
 - before cleaning
 - when the appliance is not in use
 - before changing accessories
- Do not place the appliance on a polished wood surface, it could damage the wood.
- Do not touch the metal parts, the filter holder or its housing when the appliance is in use, as this may cause burns or scalding.

- Do not place the appliance on or near a hot gas or electric burner or in a heated oven.
- This appliance conforms to directive 89/336 CEE regarding electromagnetic compatibility.
- This appliance is not intended for use by persons (including children) with reduced physical, sensory or mental capabilities, or lack of experience and knowledge, unless they have been given supervision or instruction concerning use of the appliance by a person responsible for their safety.
- Children should be supervised to ensure they do not play with the milk frother.
- Do not operate outdoors.
- Do not operate without milk in the jug.

THIS IS AN ATTENDED APPLIANCE.

- Turn the appliance and mains power off when not in use.
- Never touch rotating parts as there is a **risk of injury!**
- By exceeding the filling capacity the jug may overflow.
- Appliance to be used only in conjunction with the base unit provided.
- Never operate appliance on uneven surfaces.
- Use only fire blankets to extinguish fires on appliances.
- The appliance is not designed for commercial or industrial use; it is for household use only.
- Do not insert any objects and/or fingers in the appliance apertures.
- Disable appliances prior to disposal, cut off mains cable and take to an official refuse site.

Before first use

- Unpack the box with care, keeping all the packaging materials until you are satisfied everything is present and in working order.
- Remove all packaging and foils and store it for later use. Check if the appliance has been delivered completely and that it is in perfect order.
- Before using the appliance for the first time please clean the jug and the accessories, as described under the section “Cleaning and Care” to remove dust or production residues.

Essential Operating Instructions

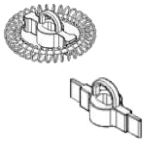

Select whisk or paddle

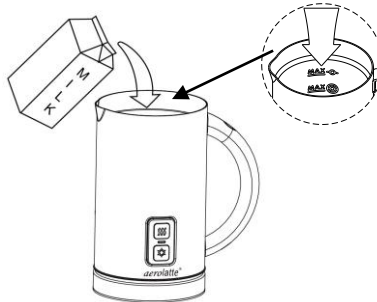



Add milk



Switch on



Hot frothed milk for perfect fluffy cappuccinos



- For best results, pre-warm the cup or mug into which you will pour the frothed milk
- Remove the lid and push the *aerolatte*[®] spiral whisk fully onto the spindle
- Fill the jug up to the **MAX**  mark (the lower max setting) with milk. Full fat or skimmed milk is best.
- Press the heat button  to heat and froth the milk.
- The button turns red and the indicator light turns blue whilst the machine is working. When finished, the blue indicator light will flash for about 30 seconds and the button light will extinguish.



Cold frothed milk for delicious thick milkshakes



- Remove the lid and push the *aerolatte*[®] spiral whisk fully onto the spindle
- Fill the jug up to the **MAX**  mark (the lower max setting) with **really cold milk**. The colder the milk, the better the quality of froth you will get.
- Press the cold button  to whisk the milk without heating.
- The button turns blue and the indicator light turns blue whilst the milk is frothing. When finished, the blue indicator light will flash for about 30 seconds and the button light will extinguish.

Hot milk with only a little touch of froth



- Remove the lid and push the warming paddle fully onto the spindle.
- Fill the jug up to the **MAX**  mark (the highest mark in the jug) with any type of milk.
- Press the hot button  to stir the milk without frothing. Note that there will be a small amount of froth generated for that perfect finish
- The button turns red and the indicator light turns blue whilst the machine is working. When finished, the blue indicator light will flash for about 30 seconds and the button light will extinguish.

Tips

- We recommend gently stirring the frothed milk with a long-stemmed spoon before serving.
- When heating, the *aerolatte*[®] compact will leave the milk at approximately 65°C, the perfect temperature for cappuccino froth. Remember, professional baristas will always pre-warm the cup before adding milk or coffee to ensure the temperate does not drop rapidly straight after pouring. You should do the same.

Recipe Variations

Caffè Macchiato: Pour freshly frothed milk into a tall glass up to about two thirds of the volume of the cup. Leave it to settle, then, very slowly, pour brewed coffee down the side of the glass. The coffee will pull the milk out of the froth to settle at the bottom and leave you with a perfect three layered caffè macchiato.

Caffè Latte: You can use the paddle to make hot milk with only a little froth on top. Pour the milk into a coffee keeping back the froth in the jug. Mix the milk with the coffee and then spoon out the small amount of froth from the jug to finish it off with a lovely white head.

Hot Chocolate: **Do not put chocolate powder or syrup into the machine.** Instead, heat and/or froth the milk and then mix with chocolate powder or sugar and cocoa in the mug. Why not try adding some orange liqueur for a treat?

Cleaning and Care

Remove the jug from the power base before cleaning.

Never immerse the jug or the power base into water.

Jug

- Clean immediately after each use and before first use.
- Wash the inside of the jug using warm soapy water and a soft cloth.
- Use the included special brush to clean any milk residue from around the spindle.
- Dry with a soft cloth.
- Do not run water across the bottom of the jug where the electrical connectors are based.

Whisk & Paddle

- Remove from the jug.
- Wash with warm soapy water.
- Dry and store in a safe place.
- The whisk and paddle can be put in the dishwasher.

Lid

- Wash in warm soapy water. The lid can be placed in a dishwasher.

Exterior body

- Clean with a soft cloth.
- **To avoid scratching the stainless steel surface, never clean with metal objects or hard brushes and never use abrasives.**

Additional Care

To keep the machine in perfect condition we suggest that you occasionally operate the machine on “hot” with water and a few drops of washing up liquid. Be sure to rinse and wipe the jug at the end of the cycle to remove any washing liquid residue.

Electrical Connection

Remember to disconnect the machine from the wall socket when not in use.

Frequently Asked Questions

How much milk should I put in?

Do not overfill with cold milk as the *aerolatte*[®] compact is so effective that it will turn the milk into almost three times as much froth and the jug might overflow. The min level (100ml) is enough for 1 cup of frothed milk. The max level (150ml) can make two cups or one big mug of full, delicious foam. **So observe the MIN and MAX marks inside the jug and ensure the lid is on firmly.**

Do I really need to wipe the inside each time?

When milk heats, the proteins will form a small layer at the bottom of the jug. This should be wiped off after each use otherwise the protein layer might burn on the next operation. This won't be a problem except that the non-stick coating is so good, that the burned milk will come off in a "skin" and may obstruct the whisking head from performing optimally.

It seems to be all froth and no milk

The machine converts milk to frothed milk. On first sight, this appears to be all foam with little milk. Over time, the foam will separate into milk and milk froth. If coffee is poured through the foam, it will draw the milk down through the froth to make the perfect cappuccino mix of 1/3 coffee, 1/3 milk and 1/3 froth.

It's overflowing with froth – what did I do wrong?

Different milks will froth to a different degree and you may get varying results. The machine has been calibrated with a variety of milks. However, please note that some milks (especially long-life milks) will froth very well and you may find that the jug overflows with the max setting. If this is the case, simply stop the machine by pressing the power button and note to use a smaller amount of milk next time.

The froth isn't as good as I expected.







Remember, that not all milk will froth. Sometimes, for no apparently explicable reason, a particular batch of milk just will not froth. Also note that the *aerolatte*[®] compact heat & froth machine works best with full fat milk. Semi skimmed milk will not give as good results. Please try another batch of milk before considering the machine to be faulty.

The lights are on but it's not working

It is possible that the *aerolatte*[®] whisking head has become stuck due to incorrect cleaning on a previous occasion. Empty the milk and clean the unit thoroughly using the "Additional Care" instructions above. Make sure you use the included brush with clean water to clean around the spindle base. With the power disconnected, use your hand to force the whisk head to rotate.

Technical data

See lid of box for details of plug attached to this machine

Model	Outline Plug Shape	Plug Definition	Voltage	Power	Certification
AG-1UK-PL		BC 1363	220V – 240V	500W	
AG-1EU-PL		CEE7/7	220V – 240V	500W	
AG-1US-PL		NEMA 5/15 CS22.2,no42	110V – 120V	500W	

Disposal

Please dispose of the packaging according to your local waste regulations. Cardboard and paper can and should be recycled. This product should never be disposed of in normal household waste at the end of its service life. It must be delivered to a collection point for the recycling of electrical and electronic goods.

Guarantee

Construction and parts for the *aerolatte*[®] compact are guaranteed for two years under normal domestic usage in accordance with these care and use instructions. A dated receipt of purchase forms part of, and proves entitlement to, this Guarantee. *aerolatte* Ltd. will gladly repair or replace at its discretion any unit found to be faulty under this guarantee. This guarantee does not affect your statutory rights. Please note that, for the avoidance of doubt, damage to the machine caused by the following **issues will not be covered by the warranty.**

- Water damage to the electrics caused by immersing the unit in water;
- Use of the machine for anything other than milk (or water for cleaning);
- Use of the machine in a professional (non domestic) environment.

